

Futaba

DIGITAL PROPORTIONAL
RADIO CONTROL

AM



INSTRUCTION MANUAL

D60638

FP-4NBL AM 4 CHANNEL



FUTABA CORPORATION OF AMERICA
FUTABA CORPORATION

*Thank you for purchasing a Futaba digital proportional radio control set.
Please read this manual carefully before using your set.*

FEATURES OF FP-4NBL

The FP-4NBL is a 4 channel AM proportional radio control set with an ergonomic case created as a result of the exhaustive pursuit of easier operation, newly designed sticks for smooth and positive operation, servo reversing switch for each channel, and other innovations based on the opinions and needs of many RC modelers.

Please read this manual before using your new set.

TRANSMITTER FP-T4NBL

- Servo reversing switch for each channel. Servos are reversed by using this switch.
- Newly designed sticks operate smoothly and positively. Spring tension mechanism allows adjustment of the operating feel of the stick lever.
- Nonslip adjustable lever head allows adjustment of the stick length as desired.
- Functional case, created as a result of the exhaustive pursuit of easier operation, has evolved a thick case which fits into the palm of the hand.
- Easy to read transmitter battery voltage/output level meter.
- Neck strap bracket provided as standard. Operation is easier if the transmitter is hung from your neck by using the neck strap.
- Nicad operation as standard.

RECEIVER FP-R114H

- High performance AM 4 channel receiver in which miniature size and light weight have been achieved by using the PC board space to the maximum.
- Narrow band ceramic filter improves rejection of adjacent channel interference.

RECEIVER WITH LINEAR CONTROLLER MCR-4A

- FET amplifier with miniature lightweight AM 4-channel receiver and motor controller in one pack.
- Since the drive motor power supply (7.2 V NiCd battery pack, etc.) can also be used to power the receiver and servos, troublesome wiring is unnecessary and the model can be made lighter.
- Built-in high performance low voltage "autocut" circuit prevents loss of control due to power supply voltage drop during flight.
- Since the motor speed can be controlled steplessly from maximum slow to high, acrobatics equal to those of engine aircraft can be reproduced even with a motor aircraft.

FEATURES OF MCR-4A RECEIVER

- Narrow band design using a narrow band ceramic filter.

FEATURES OF MCR-4A AMP

- Built-in heat protector prevents overheating of the amplifier by a continuous overcurrent.
- Motor idle or maximum slow can be arbitrarily set at the transmitter throttle stick maximum slow position by built-in idle point trimmer.

SERVO FP-S148 RUGGED, LOW-PROFILE SERVO

- Vibration and shock resistance have been improved further by using a direct wiring system which directly connects the servo amp, motor and potentiometer.
- The height of the servo has been reduced and high torque, high speed, and smooth movement equal to that of the coreless servo have been realized by using a new small, high-performance motor. (Output torque 3kg.cm, operating speed 0.22 sec/60°).

SERVO FP-S133 HIGH-QUALITY MICROSERVO

- Futaba hybrid custom 1C provides high starting output torque, narrow dead-band, and excellent trackability.
- Thick film gold plated connector pins insure positive contact connector shape increase reliability against shock and vibration. The connector housing has a reverse insertion prevention mechanism.
- Adjustable (splined) horn permits arbitrary setting of the neutral position.
- Despite being a microservo, operating speed is a fast 0.21 sec/ 60° and output torque is a high 2.2 kg/cm.

SET CONTENTS AND RATINGS

(Specifications are subject to change without prior notice.)

	FP-4NBL		
	For engine powered plane	For glider	For electric powered plane
Transmitter	FP-T4NBL x 1		
Receiver	FP-R114H x 1		MCR-4A x 1
Servo	FP-S148 x 3		FP-S133x2
Charger	FBC-8B(4) x 1		
Nicad Battery	NR-4QBx1	NR-4Kx1	
Switch	SSW-J x 1		_____
Accessories	Servo tray		_____
	Extension cord. Neck strap. Frequency flag, Spare horn. Screws		

downloaded from

<https://reparar-cochesrc.blogspot.com/>

downloaded from https://reparar-cochesrc.blogspot.com/

TRANSMITTER FP-T4NBL
Operating system : 2 stick, all channels servo reverse
Transmitting frequency : 72 MHz bands
Modulation system : AM (amplitude modulation)
Power requirement : 9.6V 500 mAH Nicad Battery
Current drain : 150mA

RECEIVER FP-R114H
Receiving frequency : 72 MHz bands
Crystal replacement system: Frequency can be changed within the same frequency band by changing the precision crystal.
Intermediate frequency 455 kHz
Power requirement 4.8 V Nicd Battery (shared with servo)
Current drain 18 mA (at 4.8 V)
Dimensions 1.3x1.87x0.78 in (33x47.4x19.8mm)
Weight 0.95 oz (27.5 g)
Receiving range 500m on the ground 1000m in the air with the **FP-T4NBL** (under best conditions)

SERVO FP-S148
Control system +pulse width control 1520 us neutral
Operating angle One side 45° or more
Power requirement 4.8V-6V
Current drain 6.0V, 12mA (at idle)
Output torque 42 oz-in (3kg.cm)
Operating speed 0.22 sec/60°
Dimensions 1.59x0.77x1.4 in (40.4x19.8x36mm)
Weight 1.5oz (44.4 g)

RECEIVER WITH LINEAR CONTROLLER MCR-4A
Dimensions 1.24x2.92x0.63 in (31.6x74.2x16.1mm) (excluding protrusion at top)
Weight 1.5 oz (44.0 g) (excluding switches and connectors)

RECEIVER
Receiving frequency 72 MHz bands
Intermediate frequency 455 kHz
Current drain 26mA
Receiving range 500m on the ground 1000m in the air with the FP-T4NBL (under best conditions)

AMP
Operating system : idle to maximum speed, no brake, idle point trimmer
Voltage : 6.0 to 8.4 V
Continuous maximum current : 100 A
Momentary maximum current : 450 A
Resistance loss : 0.01 ohm

SERVO FP S133
Control system + pulse width control 1520 us neutral
Operating angle One side 40° or greater (including trim trim)
Power supply 4.8V or 6.0V (shared with receiver)
Power consumption 6.0V, 8mA (at idle)
Output torque 30.6 oz/in (2.2 kg.cm)
Operating speed 0.21 sec/60°
Dimensions 1.10 x 0.51 x 1.14 in (28 x 13x29 mm)
Weight 0.67 oz (19g)

TRANSMITTER FP-T4NBL CONTROLS

Fig. 1 and Fig. 2 show the name of each part of the transmitter. Memorize the position and operation of each switch and control.

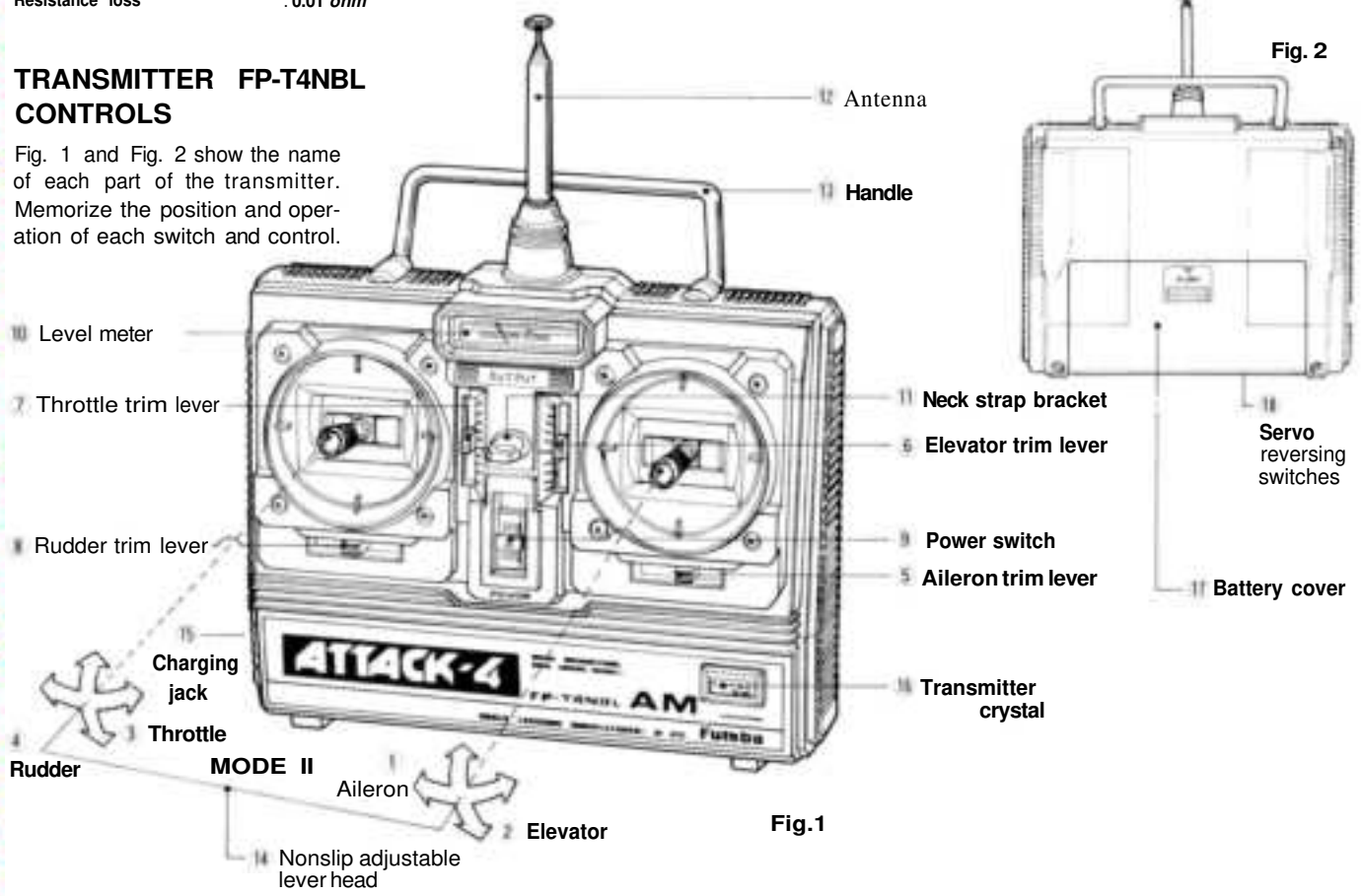

MODE I
 ② Elevator and ③ Engine throttle are opposite those shown in the figure in Mode-I.

In the following descriptions, all the servo reversing switches are assumed to be in the normal position. When they are in the reverse position, operation is the opposite of that described.

- ① **Aileron** Aileron operation
- ② **Elevator** Elevator operation
- ③ **Throttle** Throttle operation

- ④ **Rudder** Rudder operation
- ⑤ **Aileron trim lever** Aileron trimmer
- ⑥ **Elevator trim lever** Elevator trimmer
- ⑦ **Throttle trim lever** Throttle trimmer
- ⑧ **Rudder trim lever** Rudder trimmer
- ⑨ **Power switch** ON in the up position
- ⑩ **Level meter**

- This meter indicates the transmitter battery voltage.
- When the antenna is extended fully and the power switch is set to ON, the pointer should deflect to the silver zone.

- 11 Neck strap bracket
Bracket for neck strap. (Neck strap is sold separately.)
- 12 Antenna
Strong telescoping antenna. Extend it to its full length when using the transmitter.
- 13 Handle
Use this bar to carry the transmitter.
- 14 Nonslip adjustable lever head
The length of the lever head can be adjusted to suit the operator.

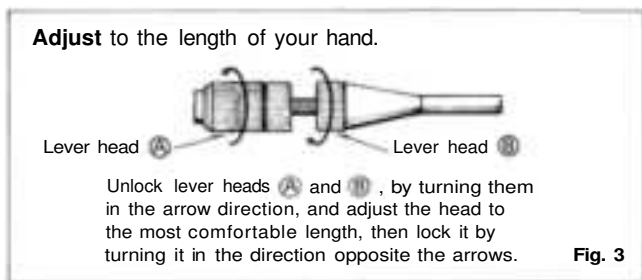

- 15 **Charging jack**
Use this jack for charging.
- 16 Transmitter crystal
- 17 **Battery cover**

Charging of transmitter and receiver Nicad batteries
Recharge the receiver and transmitter Nicad batteries as shown in Fig. 4.

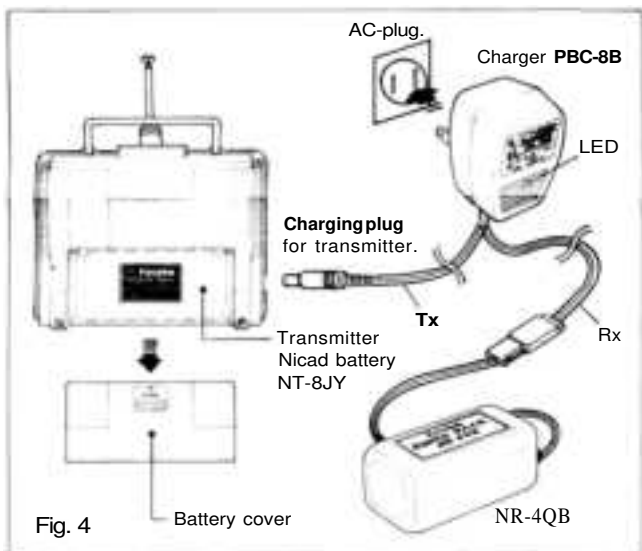

- Connect the charging plug of the dual charger to the transmitter charging jack. Connect the Rx-connector of the dual charger to the receiver Nicad battery plug, and AC-plug the dual charger to AC-outlet socket as shown in the figure.
- The receiver battery can be used about 10 times at 10 minutes per flight between rechargings.
- Charge the batteries for about 15 hours. When the set is not in use for some time, repeat discharge and charge two to three times before use. (If the batteries are not used for a long time, their capacity will go down).
- The dual charger transmitter and receiver Nicad batteries independently or simultaneously.

Notes

- 1) First connect the charger to the transmitter charge **jack**. The LED on the charger will glow **RED**.
- 2) Next connect to the receiver switch harness charge **cord**. The LED will change to **GREENISH-RED (ORANGE)**.
- 3) In the case where only one battery pack is connected, the LED color will be:
TXonly: **GREEN**
RXonly: **RED**

- 18 Servo reversing switches
- Using the servo reversing switches
- The left side of each switch is the normal position.
 - The servo reversing switches reverse the direction of operation of the servos.

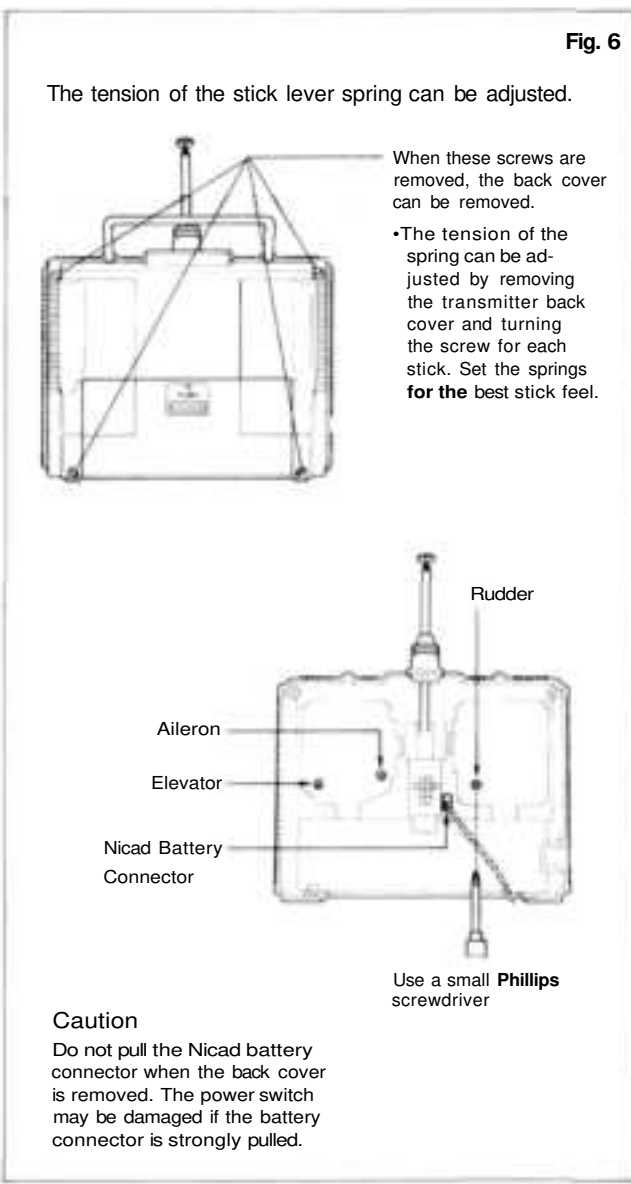
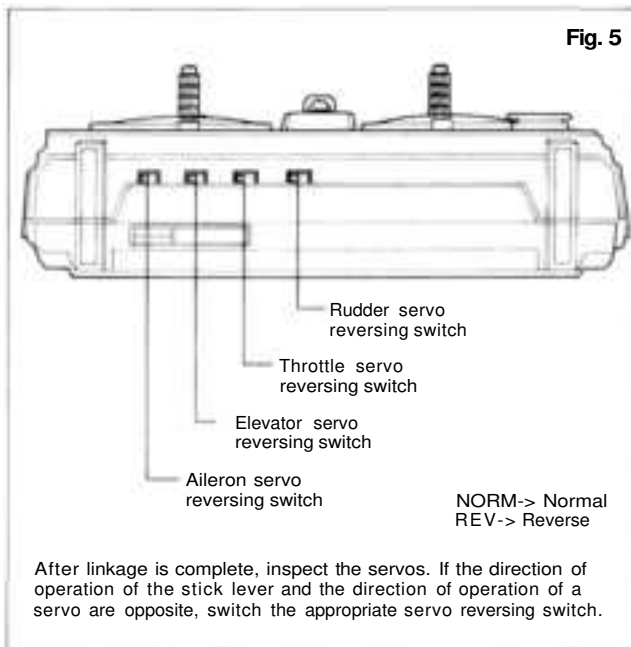

RECEIVER FP-R114H, SERVO FP-S1480R FP-S133(IN CASE OF ENGINE POWERED PLANE OR GLIDER)

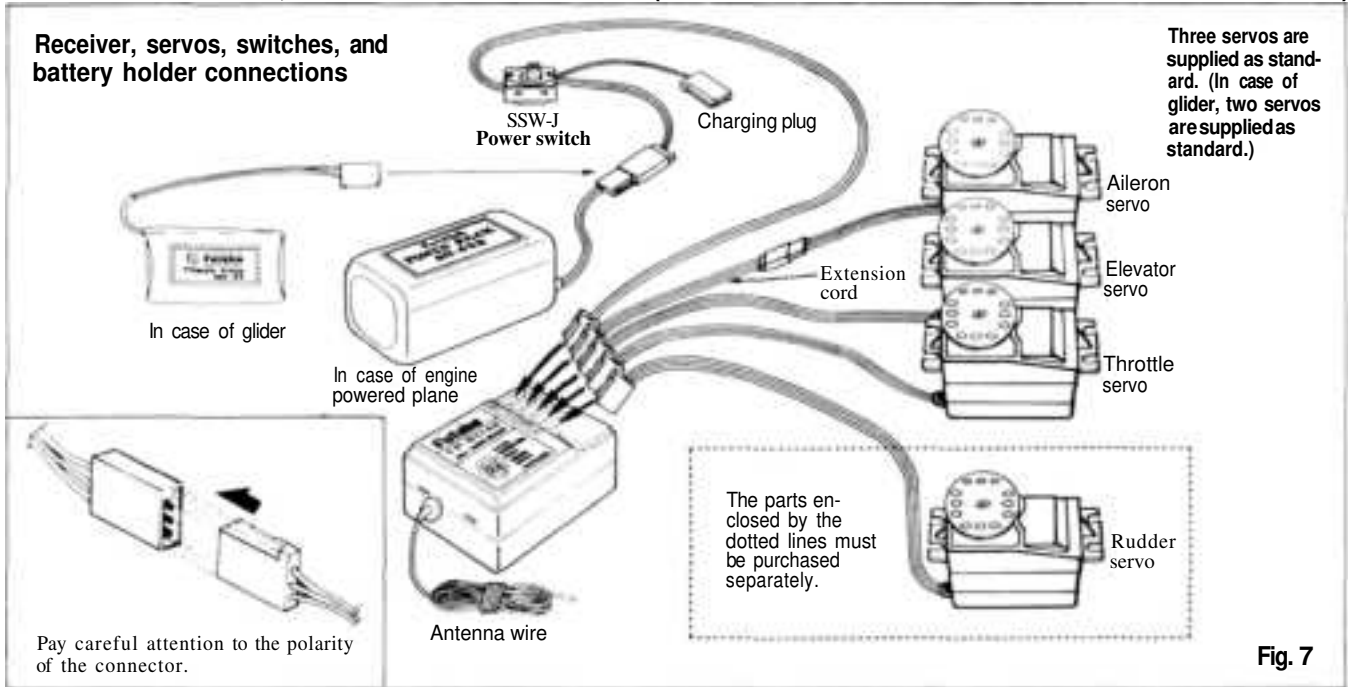

RECEIVER WITH LINEAR CONTROLLER MCR-4A, SERVO FP-S133(IN CASE OF ELECTRIC POWERED PLANE)

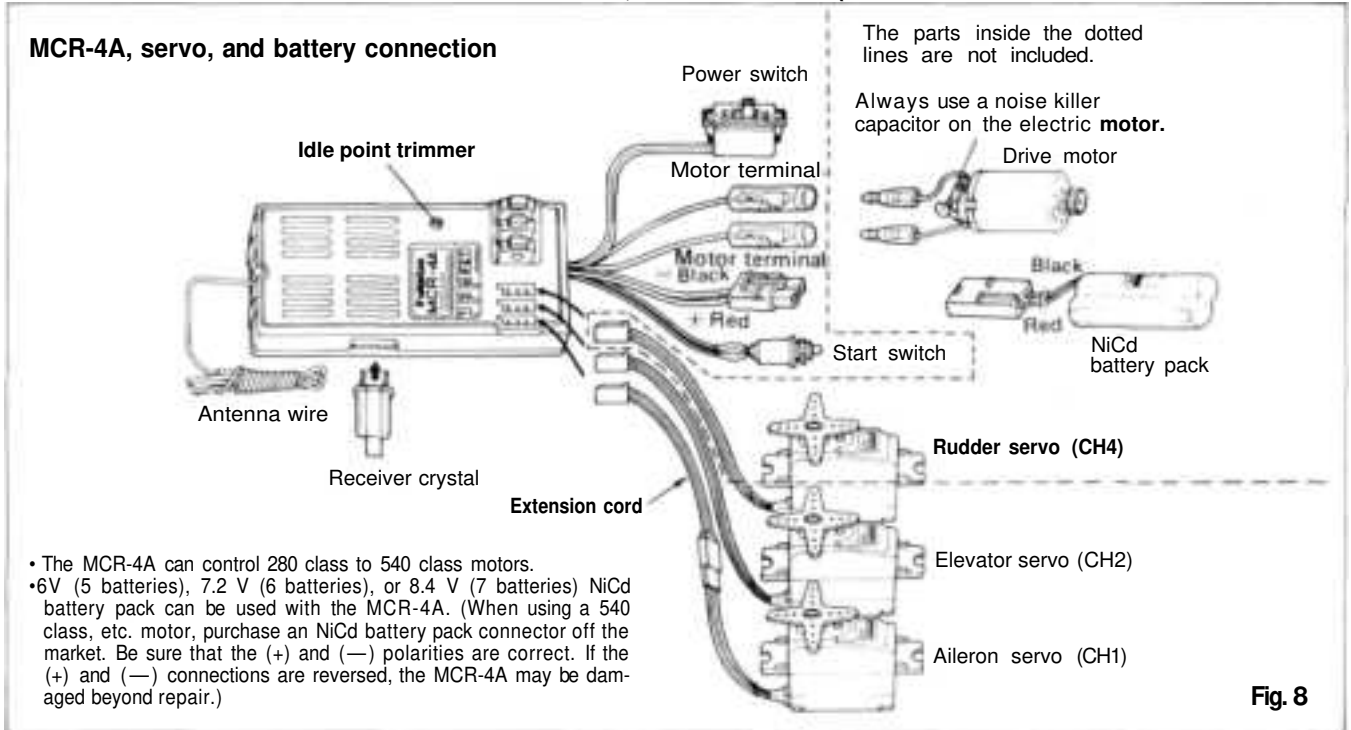

The idle point trimmer sets the drive motor idling point.

- Set the transmitter throttle servo reversing switch to the normal position.
- Set the transmit throttle stick to the slowest position (stick all the way back), turn on the MCR-4A power switch, press the start switch, and set the idle point trimmer to the point at which the motor idles.
- If the start switch is not pressed, the drive motor will **not run**.
- Turn the idle point trimmer slowly and without too much force.

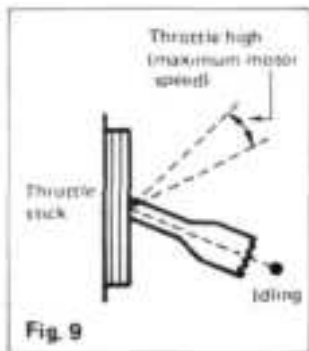

- If the drive motor rotates in the reverse direction, change the connection of the lead wire from the MCR-4A at the motor terminals.
- Before pressing the MCR-4A start switch, check that the transmitter throttle stick is in the slowest position. Starting the drive motor suddenly is dangerous. This also applies when the idle point trimmer is changed. Be very careful.
- If an overcurrent flows continuously in the motor for some reason, the heat protector will operate and stop the motor. When the temperature drops after a short time, the motor can be controlled once more. Correct the cause of the continuous overcurrent before using the set.
- The heat protector does not protect the set against momentary overcurrent caused by shorting of the drive motor lead wires, etc.
- If the drive motor is stopped **by the "autocut" function during flight**, land the aircraft immediately and safely.

PRECAUTIONS

- Connect the receiver (or MCR-4A), servos, switches, and battery firmly as shown in Fig. 7 (Fig. 8). Then extend the transmitter and receiver antennas fully.
- Set the transmitter power switch to ON. Then set the receiver (or MCR-4A) power switch to ON. The servos stop near the neutral position. Operate the transmitter sticks and check that each servo follows the movement of the stick.
- Connect the pushrod to each servo horn, then check if the direction of travel of each servo matches the direction of operation of its transmitter stick. To reverse the direction of servo travel, switch the servo reversing switch.
- Operate each servo over its full travel, and check if the pushrod binds or is too loose. Applying unreasonable force to the servo horn will adversely affect the servo and quickly drain the battery. Always make the travel of each control mechanism somewhat larger than the full travel (including trim) of the servo horn. Adjust the servo horns so that they move smoothly even when the trim lever and stick are operated simultaneously in the same direction.
- Be alert for noise.
This set is noise-resistant, but is not completely immune to noise. We recommend the use of noiseless parts and noise killer capacitor.
- When installing the switch harness, cut a rectangular hole somewhat larger than the full stroke of the switch and install the switch so that it moves smoothly from ON to OFF. This also applies to the switch mount when the switch is installed inside the fuselage and is turned on and off from the outside with a piece of wire, etc. Install the switch where it will not be exposed to engine oil, dust, etc.
- Even though the receiver antenna is long, **do not cut or bundle it.**
- Install the servos securely. Tighten the mounting screws until the rubber grommet is crushed slightly. If the screws are too tight, the cushioning effect will be adversely affected.

- Spare servo horns are supplied. Use them as needed.
- Wrap the receiver in sponge rubber. Waterproof and dust-proof the receiver by placing it in a plastic bag and wrapping a rubber band around the open end of the bag. Do the same with the receiver/servo battery.
- Use the rubber bands wrapped around the receiver to hold the servo and switch leads.
- After mounting is complete, recheck each part, then check the range by making the transmitter antenna as short as possible, extending the receiver antenna fully, and operating the set from a distance of 20m to 30m. The movement of each servo should follow the movement of each stick of the transmitter.
- The motor controller connects to channel 3 in the MCR-4A.
- Motor aircraft vibrate less than engine aircraft, **but the receiver and servo should be vibration proofed.**

•If the NiCd battery pack is connected in reverse, the MCR-4A may be damaged beyond repair. Be sure that the (+) and (−) connections are correct.

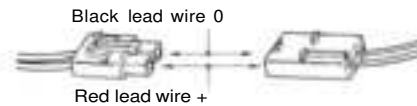

Fig. 11

- After mounting and checking are complete, take your model to the shop where you purchased the set, or to an experienced radio control modeler, and ask them to teach you how to handle your radio control set in the proper manner and to inspect your set-up carefully.
- To enjoy radio control models fully, **be sure to observe all safety standards.**

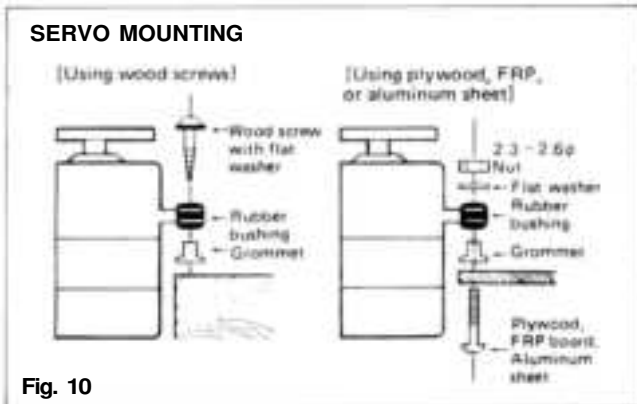

Fig. 10

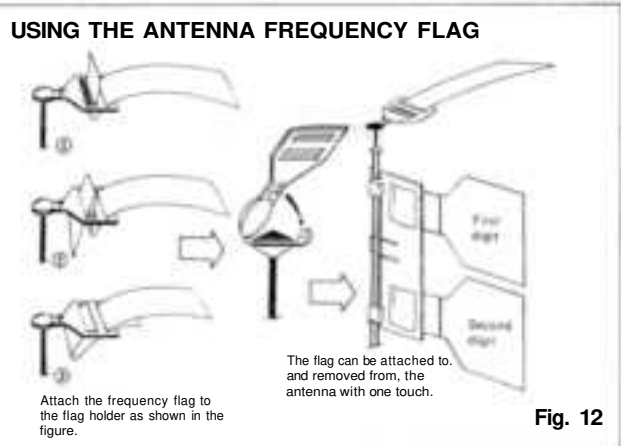

Fig. 12

SPLINED HORNS

This horn permits shifting of the servo neutral position at the servo horn. Setting and shifting the neutral position.

a) Angle divisions

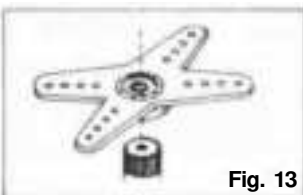

Fig. 13

- 1) The splined horn has 25 segments. The amount of change per segment is; $360 \div 25 = 14.4^\circ$.
- 2) The minimum adjustable angle is determined by the number of arms or number of the holes. For four arms, the minimum adjustable angle is:

$$\frac{360}{(25 \div 4)} = 3.6^\circ$$

Number of divisions

b) Effect

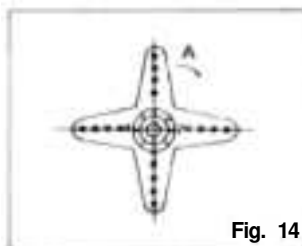

Fig. 14

To shift the holes center line to the right (clockwise) relative to baseline A, shift arm 2 to the position of arm 1 and set it to the position closest to baseline A. [Example] For a four arm horn, the angular shift per segment is 14.4° . The shift to the right is $90^\circ - (14.4 \times 6) = 3.6^\circ$. To shift by the same angle in the opposite direction, use the opposite arm number.

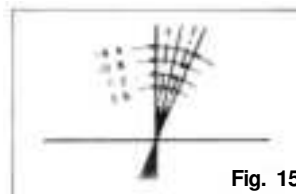

Fig. 15

For a six arm horn, turn the arm counterclockwise and set arm 2 to the position of arm 1. The adjustable angle is $60^\circ - (14.4 \times 4) = 2.4^\circ$.

Arm 3 shift 4.8° to the right, arm 6 shifts 2.4° to the left, and arm 4 shifts 7.2° to the right and left.

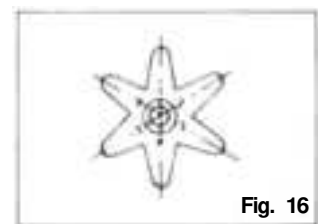

Fig. 16

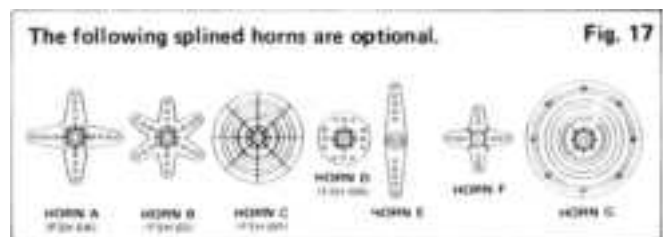
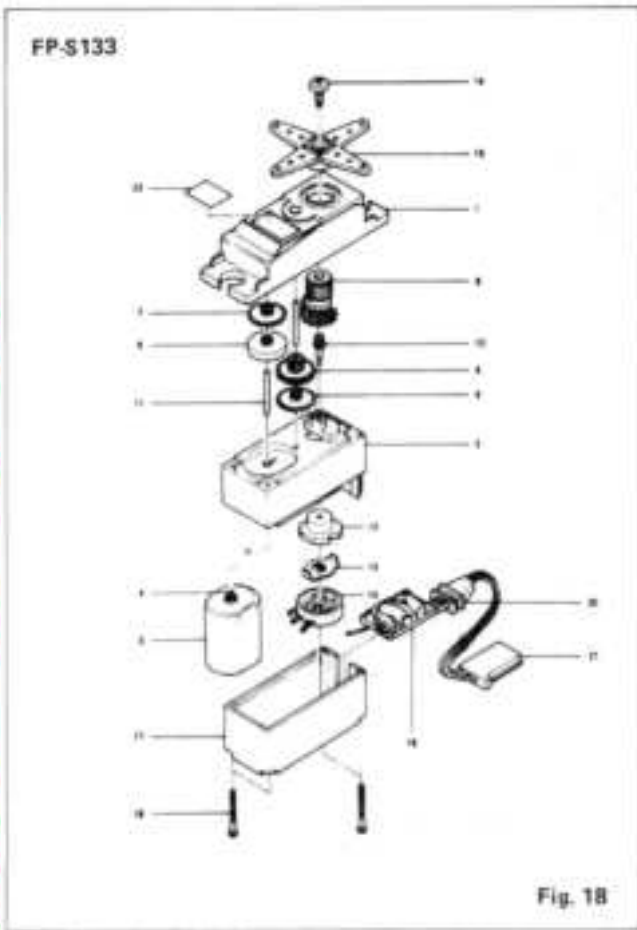
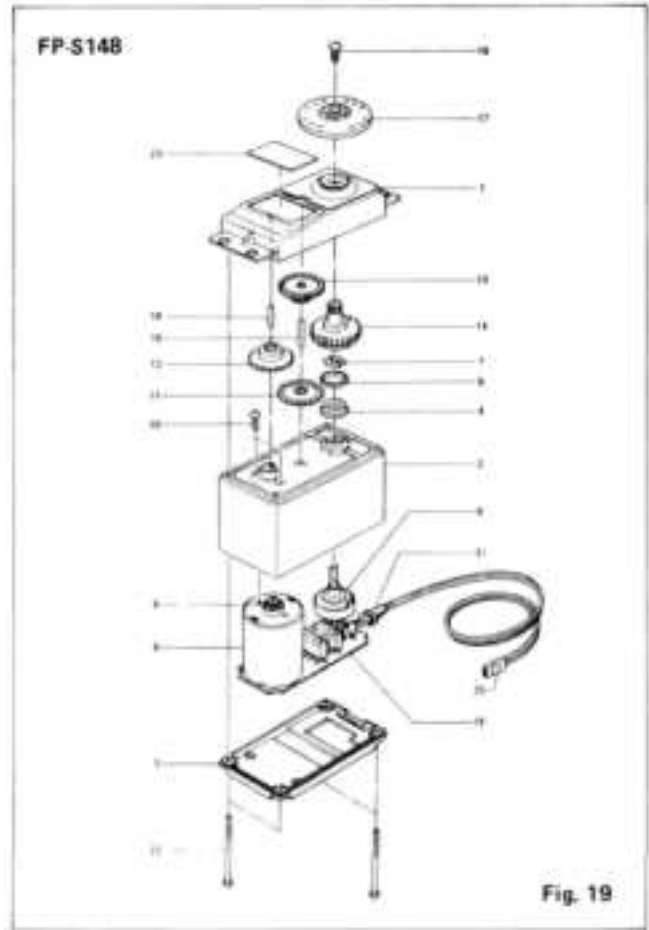

Fig. 17



No.	Part name	Part No.
1	Upper case	S05850
2	Middle case	S05860
3	Motor	S91241
4	Motor pinion	S02781
5	1st gear	S02782
6	2nd gear	S02783
7	3rd gear	S02784
8	4th gear	S02785
9	Final gear	S02786
10	Output shaft	S05880
11	Intermediate shaft	S04285
12	VR joint	S05872
13	VR drive plate	S05626
14	Potentiometer	i39600
15	Splined horn F	S01241
16	Horn mounting screw	J55171
17	Bottom case	S05870
18	Case mounting screw	S40070
19	Printed wiring board	AS 1259
20	Grommet	S90045
21	3PC cord 170	AT2213
22	Name plate	S60122



No.	Part name	Part No.
1	Upper case	VCS-48
2	Middle case	FCS-48
3	Bottom case	FCS-48
4	Metal bearing	S04137
5	Metal bearing	S04136
6	Potentiometer	139668
7	Potentiometer drive plate	S02753
8	Motor	S91239
9	Motor pinion	S02461
10	Screw	J50002
11	1 st gear	FGS-48
12	2nd gear	FGS-48
13	3rd gear	FGS-48
14	Final gear	FGS-48
15	Intermediate shaft	S02495
16	2nd shaft	S02494
17	Servo horn D	PSH-6W
18	Binding head tapping screw 2.6x8	FSH-41
19	Printed wiring board	ASH 57
20	3PB-WRB300G	AT2453
21	w/gum bush	S90045
22	Pan head truss screw	S50360
23	Nameplate	S60099



FUTABA CORPORATION

Makuhari Techno Garden Bldg., B6F 1-3 Nakase, Mihama-ku, Chiba 261-01, Japan
 Overseas Marketing & Sales Radio Control Systems
 Phone: (043)296-5119 Facsimile: (043)296-5124

FUTABA CORPORATION OF AMERICA

4 Studebaker, Irvine California 92718, U.S.A.
 Phone: 714-455-9888 Telex: 23-0691227 Facsimile: 714-455-9899